

***K-LINE* High Power Resistors**

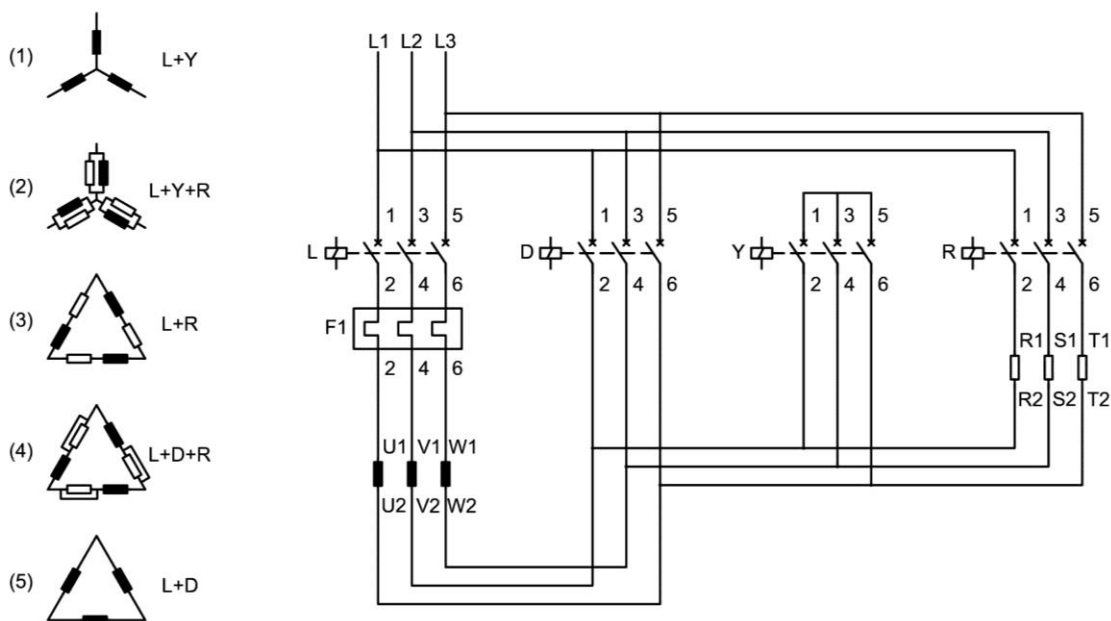

***K-LINE* KRS** series resistors are specially designed for use in closed transition star-delta motor starters. Closed transition star-delta starter prevents an interruption of the motor current during switch-over from star to delta, hence the motor speed remains practically constant. Therefore, the current peak during switch-over is kept at low level. The resistor is of wire wound, housed in an aluminium casing for mechanical protection and better heat dissipation. The resistor is rated at 12 starts per hour and 3 resistors are required for each starter.

Wiring Diagram for Closed Transition Star-Delta Starter



Wiring Diagram for Closed Transition Star-Delta Starter

Resistor Dimensions and Selection Table

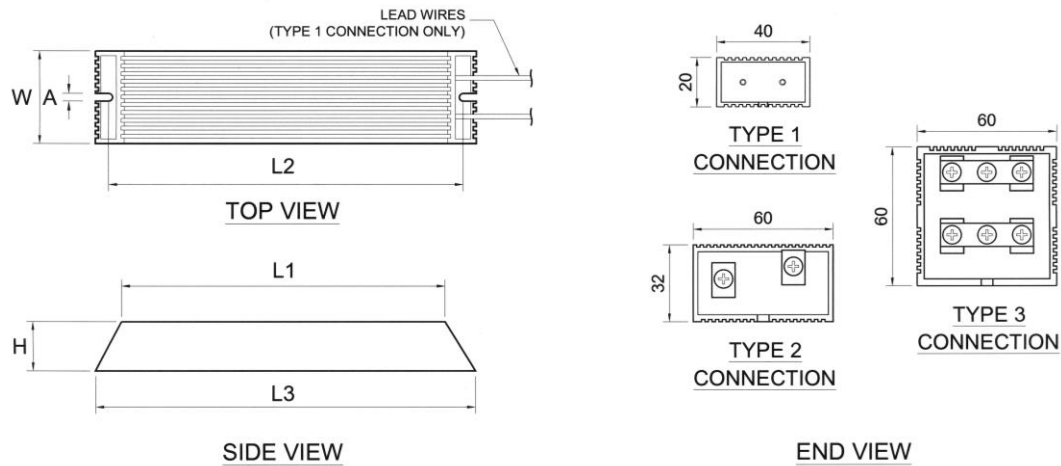

Model	For 415V 3Ph 50Hz Motor		Dimensions (mm)						Connections
	Rating (KW)	F.L.C. (A)	L1 ± 1.5	L2 ± 1.5	L3 ± 1.5	H ± 1	W ± 1	A ± 0.5	
KRS/415-5.5	5.5	11	72	85	100	20	40	5	Type 1 250mm Lead Wires
KRS/415-7.5/9	7.5 / 9	14 / 17	72	85	100	20	40	5	
KRS/415-11/15	11 / 15	21 / 28	72	85	100	20	40	5	
KRS/415-18.5	18.5	35	82	95	110	20	40	5	
KRS/415-22/30	22 / 30	40 / 55	112	125	140	20	40	5	
KRS/415-37/45	37 / 45	66 / 80	162	175	190	20	40	5	
KRS/415-55	55	100	128	153	168	32	60	5	Type 2 Terminals
KRS/415-75	75	135	128	153	168	32	60	5	
KRS/415-90	90	165	202	227	242	32	60	5	
KRS/415-110	110	200	202	227	242	32	60	5	
KRS/415-132	132	240	300	325	340	32	60	5	
KRS/415-160	160	280	300	325	340	32	60	5	
KRS/415-200	200	340	365	385	400	60	60	5	Type 3 Terminals
KRS/415-220	220	385	365	385	400	60	60	5	
KRS/415-250	250	425	465	485	500	60	60	5	
KRS/415-280	280	475	465	485	500	60	60	5	
KRS/415-315	315	535	465	485	500	60	60	5	

Note: Three resistors are required for each starter.

Rickson Engineering Ltd.
21/F, Sun Hing Ind. Building,
46 Wong Chuk Hang Road, Hong Kong.

Tel: (852) 3120 7500

利信機電有限公司
香港黃竹坑道 46 號
新興工業大廈 21 字樓

Fax: (852) 3120 7511

Email: general@rickson.com.hk
Website: <http://www.rickson.com.hk>